

FEMALE HOUSING 6 WAYS
WITH PRESS PEG

R694.262.906

Series : MCC2

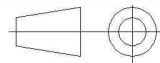
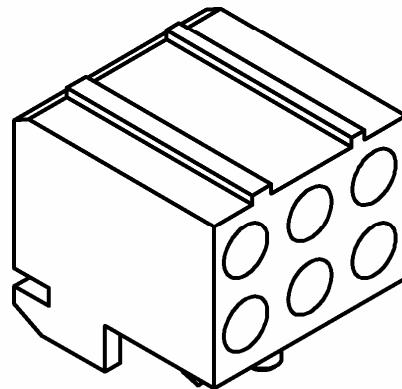
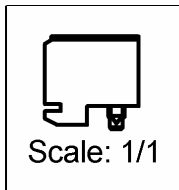
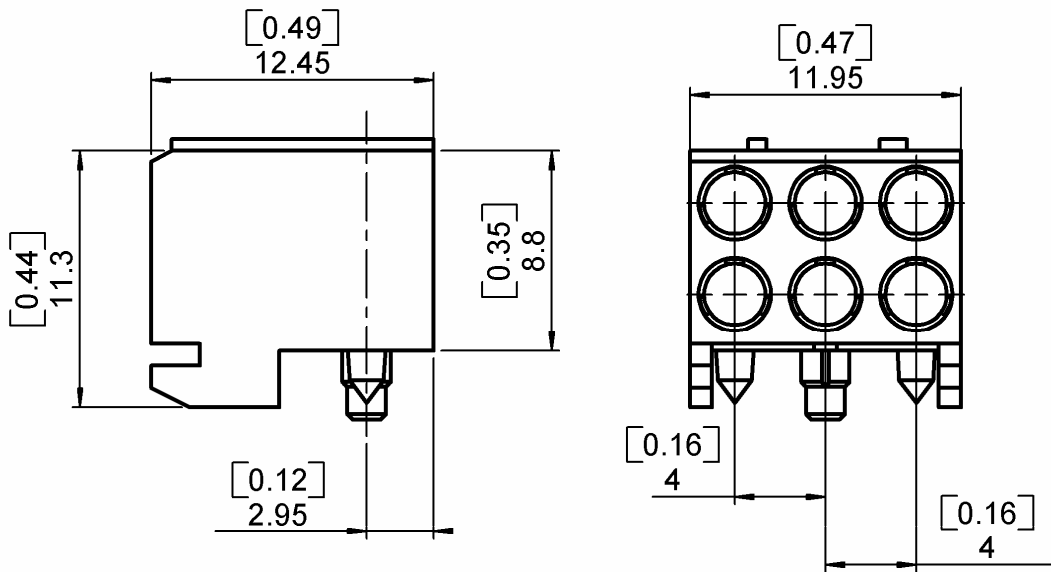

All dimensions are in mm.

COMPONENTS	MATERIALS	PLATING (µm)
BODY	LIQUID CRISTAL POLYMER	-
CENTER CONTACT	-	-
OUTER CONTACT	-	-
INSULATOR	-	-
GASKET	-	-
OTHERS PARTS	-	-
-	-	-
-	-	-

Issue : 0743 A

In the effort to improve our products, we reserve the right to make changes judged to be necessary.



FEMALE HOUSING 6 WAYS
WITH PRESS PEG

R694.262.906

Series : MCC2

PACKAGING

SPECIFICATION

Standard	Unit	Other
1	-	Contact us

ELECTRICAL CHARACTERISTICS

ENVIRONMENTAL

Impedance	NA	Ω
Frequency	NA	GHz
VSWR	NA + 0,0000	x F(GHz) Maxi
Insertion loss	NA	$\sqrt{F}(\text{GHz})$ dB Maxi
RF leakage	NA - (F(GHz)) dB Maxi
Voltage rating	NA	Veff Maxi
Dielectric withstanding voltage	NA	Veff mini
Insulation resistance	NA	M Ω mini

Operating temperature	-25/+125	$^{\circ}\text{C}$
Hermetic seal	NA	Atm.cm ³ /s
Panel leakage	NA	

OTHER CHARACTERISTICS

Assembly instruction

Others :

MECHANICAL CHARACTERISTICS

Center contact retention		
Axial force – Mating end	NA	N mini
Axial force – Opposite end	NA	N mini
Torque	NA	N.cm mini
Recommended torque		
Mating	NA	N.cm
Panel nut	NA	N.cm
Mating life	0	Cycles mini
Weight	1,3230	g

Issue : 0743 A

In the effort to improve our products, we reserve the right to make changes judged to be necessary.

